

Sales Drawing

Electrical Testing

As Xiangwei standard test plans and Mil-Std-202 Test Method.

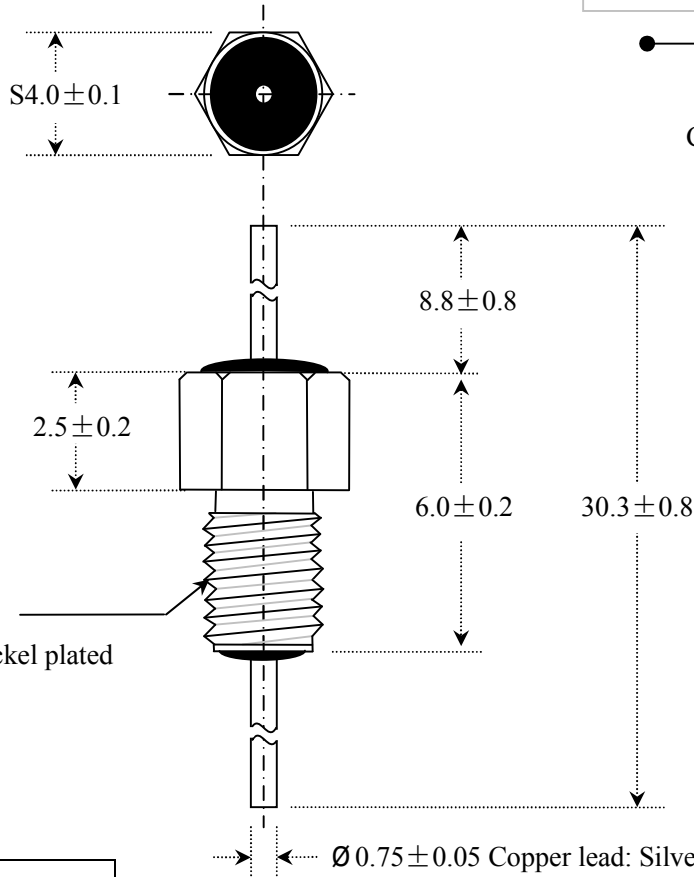
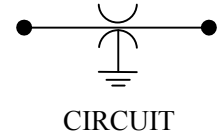
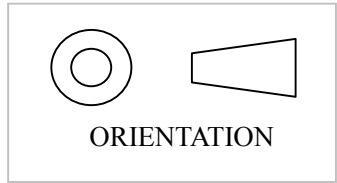

SPECIFICATIONS	
Capacitance	1000pF
Dissipation Factor	< 3.5%
Capacitance Tolerance	-20%+80%
Temp Characteristics	X7R
Rating Voltage	100VDC
DWV	300VDC
Current	7A
I.R.100vdc	3000MΩ
Operating Range	-55°C+125°C

Notes:

1. Do not use a hard object beat capacitor body.
2. Storage: Usual temperature by sealed.
3. Soldering: Using constant electric iron soldering, and don't use furnace welding and dip soldering methods.
4. ROHS Part (Lead free).

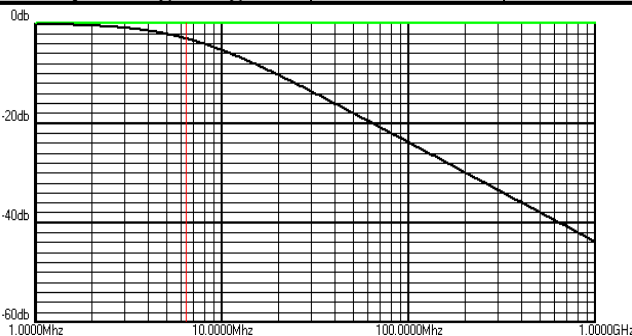

Install Torque

6kgf • cm

Soldering Temp: ≤300°C

Soldering Time: 3sec

LCA®

LCA

Micronics

Unit: (mm)

L4030-034N